

XB895

ELECTRIC

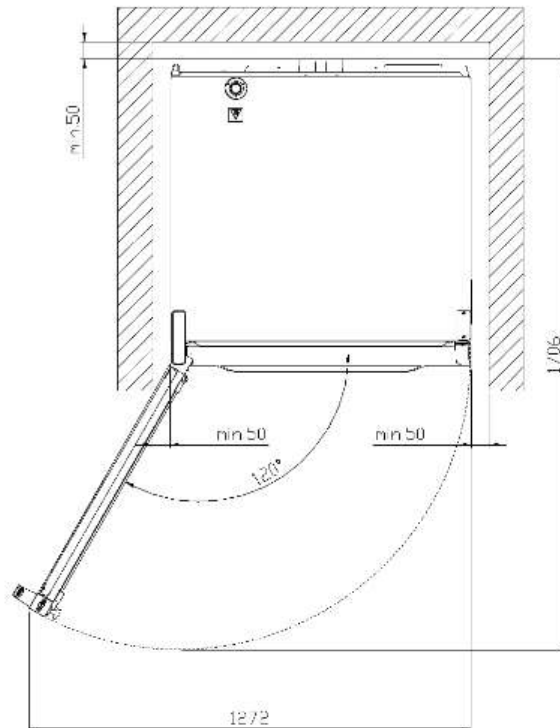

capacity	10 600x400
distance	80 mm
frequency	50 / 60 Hz
Voltage	400 V~ 3N
power	15,8 kW
heat power	-
Dimensions	860x882x1250
weight	112 Kg

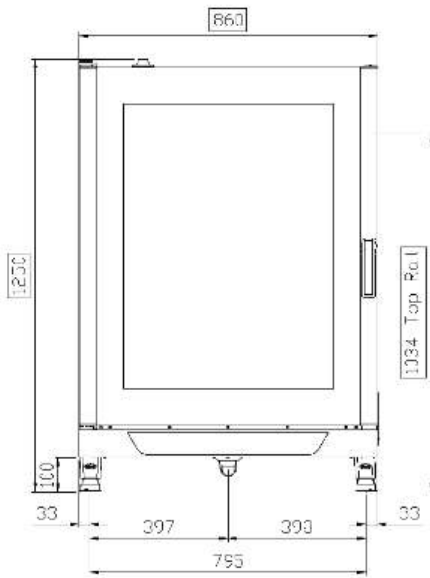
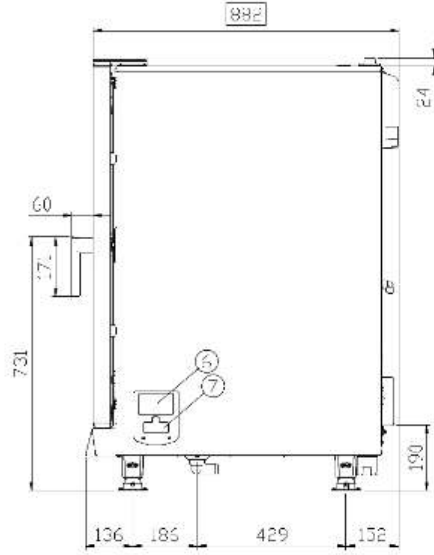
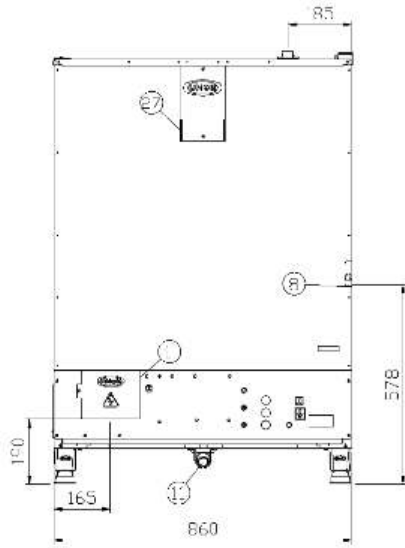

	DYNAMIC	MANUAL
■ :Standard □ :Optional - :Not available		
BAKING MODES		
Convection baking 30 °C - 260 °C	■	■
Convection baking + Humidity 48 °C a 260 °C	■	■
Maximum pre-heating temperature 260 °C	■	■
AIR DISTRIBUTION IN THE BAKING CHAMBER		
AIR.Plus technology: multiple auto-reversing fans	■	■
AIR.Plus technology: dual fan speeds	■	■
CLIMA MANAGEMENT IN THE BAKING CHAMBER		
DRY.Plus technology: rapid humidity extraction	■	■
STEAM.Plus technology: humidity setting from 20 to 100%, programmable by the user	■	-
STEAM.Plus technology: manual humidity activation	-	■
HIGH PERFORMANCE ATMOSPHERIC BURNER		
Spido.GAS™ technology: suitable for G20 / G25 / G30 / G31 gas types (only for gas ovens)	-	■
Spido.GAS™ technology: straight heat exchanger pipes for an easy service (only for gas ovens)	-	■
PATENTED DOOR		
Door hinges made of high durability and self-lubricating techno-polymer	■	■
Reversible door, even after the installation (not for 16 600x400 models)	■	■
Door docking positions at 60°-120°-180°	■	■
AUXILIARY FUNCTIONS		
99 baking programs memory, each one made of 3 baking steps + pre-heating	■	-
Protek.SAFE™ technology: maximum thermal efficiency and working safety (cool door glass and external surfaces)	■	■
Visualisation of the residual baking time	■	■
Continuous functioning «INF»	■	■
Visualisation of the nominal value of baking chamber temperature	■	-
«COOL» function for rapid chamber cooling	■	-
Temperature unit in °C or °F	■	-
TECHNICAL DETAILS		
Rounded stainless steel AISI 304 baking chamber for hygiene and ease of cleaning	■	■
Cavity lighting through external LED lights (only for 16 600x400 model)	-	■

Cavity lighting through long-life halogen lights (only for 10 and 6 600x400 models)	■	■
High-durability carbon fibre door lock	■	■
Side opening internal glass to simplify the door cleaning	■	■
Stainless steel L-shaped rack rails	■	■
Light weight – heavy duty structure using innovative materials	■	■
Autodiagnostic system	■	-
USB and LAN port	0	-
Safety temperature switch	■	■