

# MENUMASTER<sup>®</sup> Commercial

Project #: \_\_\_\_\_

Item #: \_\_\_\_\_



## High Speed Oven Menumaster<sup>®</sup> Commercial Xpress IQ™ MRX Series

### Superior cooking results FAST!

- Enhanced cavity airflow for perfect browning & crisping
- 3000W impingement enhances toasting and browning.
- Easily adjustable 0-100% fan speed.
- 95° - 270°C (200° - 520°F) temperature range cooks a variety of items
- 1000 or 2000W top antenna feed microwave system heats quickly, reduces cooking time.

### Minimized footprint, maximized cavity design

- Compact footprint fits on 71 cm (28") deep counter.
- Flexibility to install with or without 10cm (4") leg kit
- Easily accommodates a 30cm (12") pizza

### Multi-language universal operation, with programming flexibility:

- Touchscreen and programming software supports 25 languages
- Image-based menu selection eliminates language and literary barriers
- Connectivity Standard: WiFi, Ethernet, and Smart USB standard

### Appropriate for front-of-house display

- Sleek, contemporary styling
- True-Touch™ HD Touchscreen. Fully customizable 178mm (7") smartphone-like display
- Catalytic converter built-in for ventless operation.
- Quiet operation: fan speeds auto-adjust based on operation mode

### Safe operation and simple cleaning

- Inner door drops down below cooking surface for safe removal of food from cavity
- Smooth door surface allows for direct application of approved cleaners
- Non-stick oven liners preinstalled for easy cleaning
- Clean magnetic air filters in one-step
- Automatic Voltage Sensor adjusts to the power supply. (North America only)
- Rapid cool down allows for expedited end-of-day cleaning

### Included Accessories:

- Cook plate (CP10)
- Compact oven paddle (PA10R)
- Non-stick liners (TL10R)

### Optional Accessories

- Panini grill plate (RGR10)
- Pizza Stone(ST10R)
- 4" (102mm) Leg kit (LG10)
- Oven paddle (PA10)
- Non-stick baskets (TB10S, SB10S, MB10S)
- Back Cover Panel (BC10R)
- Top storage shelf (TS10R)
- Stainless dual-oven stacking cart (SC10R)
- Stainless cart/equipment stands: (CA24, CA30)
- Oven Cleaner and Shield Protectant (CL10\*, SH10\*, CL10W\*\*, PR10W\*\*)

15 times faster than conventional ovens.

**Xpress® Line | Heavy Volume**  
This category of high speed oven is ideal for...

#### Applications

- Convenience Stores
- Healthcare
- Delis
- Satellite Locations
- Hotel Room Service
- QSR
- Coffee Shops
- Snack Bars
- Bars/Pubs

#### Through put potential (per hour)

Food item	MRX 1000W	MRX 2000W
30cm (12") frozen pizza	18	21
15cm (6") toasted sandwiches	60	80
Grilled fresh Salmon	22	28
0.45kg (1 lb.) fresh shrimp	55	55
Toasted Bagel	120	120
Chicken wings	15	24
Quesadillas	65	70

#### Location of Oven(s):

- Kitchen countertop
- Front-of-house countertop
- Equipment stand
- Oven stacking cart (available accessory)

All ACP, Inc. commercial ovens are supported by our Culinary Center. Do not hesitate to contact us for any questions regarding food preparation, menu development and cooking times: [testkitchen@acpsolutions.com](mailto:testkitchen@acpsolutions.com)



#### Service

All products are backed by the ACP, Inc. 24/7 ComServ Support Center



#### Warranty

Warranty Certificate for this product can be found on the ACP, Inc. website at [www.acpsolutions.com/warranty](http://www.acpsolutions.com/warranty).



#### Safety and Sanitation

This ACP, Inc. product meets and exceeds safety and sanitation standards set for commercial microwave ovens by UL, ETL, NSF, CSA, FDA, ETL EU and CE



AIA File #:

Specification #:

\*Only shipped in U.S.A.  
\*\* Only shipped in Europe



© 2018 ACP, Inc.  
Cedar Rapids, Iowa 52404

# MenuMaster® Commercial Xpress IQ™ MRX Series | High Speed Oven

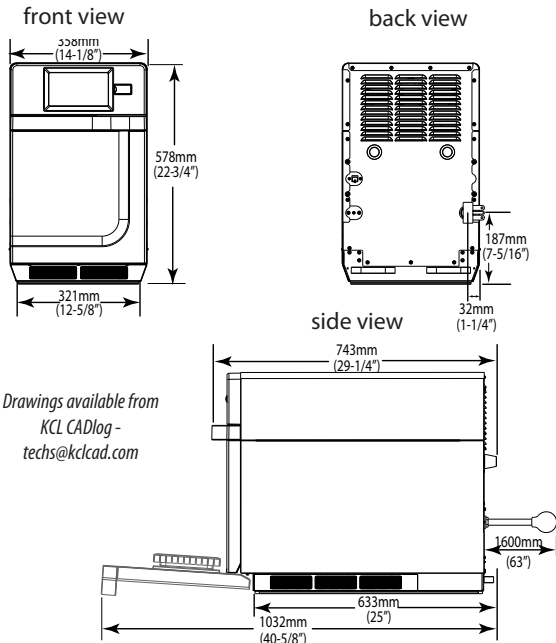

Drawings available from  
KCL CADlog -  
techs@kclcad.com

## Features

Configuration	Countertop
Stackable	Yes, with kit
Display	178 (7") Capacitive Touch, High resolution LCD display
USB Port	Yes
Connectivity	Wifi and Ethernet
Program Menu	Tab & Multi-level menu capability
Menu Capacity	1200+ items
Max. Cooking Time	99:99
Temperature Range	95° - 270°C (200° - 520°F)
Microwave Distribution	Rotating antennas, top
Fan Speed	0-100%
Power Levels	11
Defrost	Yes, microwave only, power level 2
Time Entry Option	Yes
Stage Cooking	Yes, 4
Catalytic Converter	Yes†
Automatic Voltage Sensor	Yes (North America only)
Air Filter	3 removable, with clean filter reminder
Rack	Removable cooking surface
Door Opening	Pull down, ergonomic handle
Exterior Finish	Stainless steel and Painted Steel
Interior Finish	Stainless steel

## Weight

Model Type	Product Weight	Ship weight (approx.)
1x Mag	53 kg (116 lbs.)	61 kg (134 lbs.)
2x Mag	61 kg (134 lbs.)	69 kg (152 lbs.)

## Dimensions

Exterior	H 578 (22 3/4")	W 358 (14 1/8")	D† 743 (29 1/4")
Cavity	H 178 (7")	W 312 (12 1/4")	D 312 (12 1/4")
Usable Cavity Space	17.2 liter (0.61 cubic ft.)		
Door Depth	1032 (40 5/8"), drop down door		
Installation Clearances	Top: 51 (2")	Sides: 13 (1/2")	Back: None
Shipping Carton	H 635 (25")	W 457 (18")	D 902 (35 1/2")

## Electrical Configuration

	Region	Model#/ UPC Code	Power Consumption	Power Output*		Power Source	Plug Configuration	Cord Length	Frequency
				Microwave	Impingement				
2x Mag	North America single phase	<b>MRX2</b> 728028422849	5950 W, 28.6 A	2000 W*	3000 W	208-240V, 60 Hz, 30 A, single phase	NEMA 6-30	1.5m (5 ft.)	2450 MHz
	EMEA, SEA, LATAM single phase	<b>MRX52</b> 728028422887	5950 W, 28.6 A	2000 W*	3000 W	230-240 V, 50 Hz, 32 A, single phase	IEC 309	1.5m (5 ft.)	2450 MHz
	EMEA, SEA, LATAM multi phase	<b>MRX523</b> 728028422900	5950 W, 16 A	2000 W*	3000 W	400V, 50 Hz, WYE, 16 A, 3 phase, 5 wire	IEC 309	2.4m (8 ft.)	2450 MHz
	Brazil single phase	<b>MRX2B</b> 728028423259	5550 W, 25.8 A	2000 W*	3000 W	220V, 60 Hz, 32 A, single phase	IEC 309	1.5m (5 ft.)	2450 MHz
	Saudi Arabia single phase	<b>MRX2SA</b> 728028423273	5550 W, 25.8 A	2000 W*	3000 W	220V, 60 Hz, 32 A, single phase	Direct Wire	2.4m (8 ft.)	2450 MHz
1x Mag	North America single phase	<b>MRX1</b> 728028422825	3600 W, 18.2 A	1000 W*	3000 W	208-240 V, 60 Hz, 20 A, single phase	NEMA 6-20	1.5m (5 ft.)	2450 MHz
	EMEA, SEA, LATAM single phase	<b>MRX51</b> 728028422863	3680 W, 16 A	1000 W*	3000 W	230-240 V, 50 Hz, 16 A, single phase	CEE 7/7 "Schuko"	1.5m (5 ft.)	2450 MHz
	EMEA (UK), SEA single phase	<b>MRX51U</b> 728028423006	2450 W, 13 A	1000 W*	3000 W	230-240 V, 50Hz, 13 A, single phase	BS1363/A	1.5m (5 ft.)	2450 MHz
	Australia single phase	<b>MRX51A</b> 728028423044	3250 W, 15 A	1000 W*	3000 W	230-240 V, 50Hz, 15 A, single phase	A53112	1.5m (5 ft.)	2450 MHz
	Brazil single phase	<b>MRX1B</b> 728028423211	3550 W, 16.7 A	1000 W*	3000 W	220V, 60 Hz, 16 A, single phase	NBR 14136	1.5m (5 ft.)	2450 MHz
	Saudi Arabia single phase	<b>MRX1SA</b> 728028423235	3550 W, 16.7 A	1000 W*	3000 W	220V, 60 Hz, 16 A, single phase	Direct Wire	1.5m (5 ft.)	2450 MHz

Also available in colors. For details: [www.acpsolutions.com/xpress-iq/color](http://www.acpsolutions.com/xpress-iq/color)

Measurements are millimeters. Measurements in ( ) are US Standard

\* IEC 60705 Tested

† Includes handle

‡ Catalytic convertor filters grease and odors from the air. This product conforms to the Ventless Operation Recommendations set forth by NFPA96 using EPA202 test method

EMEA = Europe, the Middle East and Africa; SEA=South East Asia; LATAM=Latin America

Part No. 20218002  
Updated 7/23/2018  
Original Instructions

225 49th Ave. Dr. SW Cedar Rapids, IA 52404 U.S.A.

800-233-2366

319-368-8120

Fax: 319-368-8198

© 2018 ACP, Inc.  
Cedar Rapids, Iowa 52404



[www.acpsolutions.com](http://www.acpsolutions.com)

Specification #:

AIA File #: